

**Детали трубопроводов бесшовные приварные из углеродистой  
и низколегированной стали**

**ПЕРЕХОДЫ**

**Конструкция**

Carbon and low-alloy steel butt-welding fittings. Reducers. Design

Дата введения 2003—01—01

### 1 Область применения

Настоящий стандарт распространяется на бесшовные приварные концентрические и эксцентрические переходы из углеродистой и низколегированной стали.

Область применения переходов — в соответствии с разделом 1 ГОСТ 17380.

Требования пунктов 4.1 — 4.3 и раздела 5 являются обязательными, остальные требования — рекомендуемыми.

### 2 Нормативные ссылки

В настоящем стандарте использована ссылка на ГОСТ 17380—2001. Детали трубопроводов бесшовные приварные из углеродистой и низколегированной стали. Общие технические условия

### 3 Определения, обозначения и сокращения

Термины, их определения, обозначения и сокращения — по ГОСТ 17380.

### 4 Конструкция и размеры

4.1 Конструкция и размеры переходов должны соответствовать указанным на рисунке 1 и в таблицах 1 и 2.



Рисунок 1

Т а б л и ц а 1 — Переходы исполнения 1

Размеры в миллиметрах

DN	<i>D</i>	<i>T</i>	<i>D</i> <sub>1</sub>	<i>T</i> <sub>1</sub>	<i>L</i>	Масса, кг
20	26,9	2,0	21,3	2,0	38	0,05
		3,2		3,2		0,07
25	33,7	4,0	21,3	4,0	51	0,09
		2,3		2,0		0,12
25	33,7	3,2	26,9	3,2	51	0,16
		4,5		4,0		0,09
32	42,4	2,3	21,3	2,0	51	0,12
		3,6		3,2		0,16
32	42,4	5,0	21,3	4,0	51	0,23
		2,6		2,0		0,13
32	42,4	3,6	26,9	3,2	51	0,17
		5,0		4,0		0,23
32	42,4	2,6	33,7	2,3	51	0,13
		3,6		3,2		0,17
32	42,4	5,0	33,7	4,5	51	0,23
		2,6		2,0		0,13
40	48,3	3,6	26,9	3,2	64	0,25
		5,0		4,0		0,34
40	48,3	2,6	33,7	2,3	64	0,19
		3,6		3,2		0,25
40	48,3	5,0	33,7	4,5	64	0,34
		2,6		2,6		0,19
40	48,3	3,6	42,4	3,6	64	0,25
		5,0		5,0		0,34
50	60,3	2,9	33,7	2,3	76	0,31
		4,0		3,2		0,42
50	60,3	5,6	33,7	4,5	76	0,58
		2,9		2,6		0,31
50	60,3	4,0	42,4	3,6	76	0,42
		5,6		5,0		0,58
50	60,3	2,9	48,3	2,6	76	0,31
		4,0		3,6		0,42
50	60,3	5,6	48,3	5,0	76	0,58
		2,9		2,6		0,31
65	76,1	2,9	42,4	2,6	89	0,47
		5,0		3,6		0,78
65	76,1	7,1	42,4	5,0	89	1,10
		2,9		2,6		0,47
65	76,1	5,0	48,3	3,6	89	0,78
		7,1		5,0		1,10

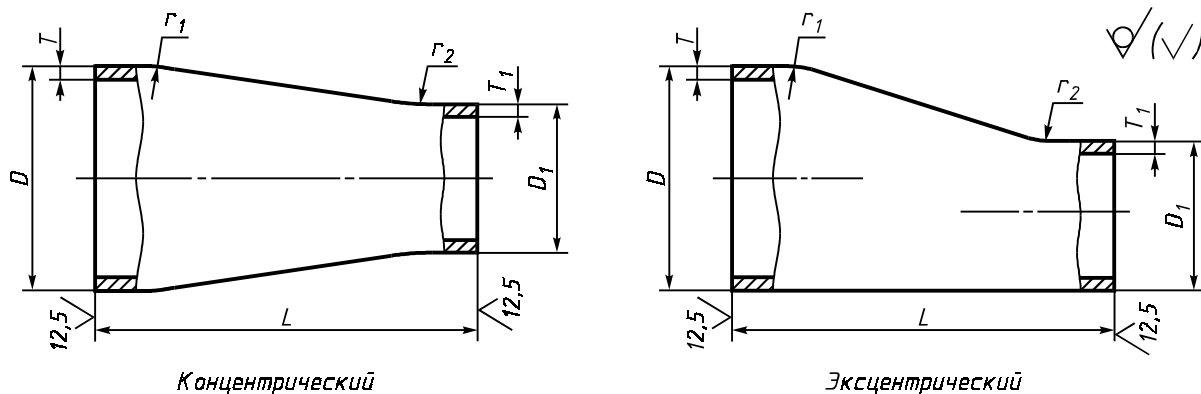
## ГОСТ 17378—2001

Продолжение таблицы 1

Размеры в миллиметрах

DN	<i>D</i>	<i>T</i>	<i>D</i> <sub>1</sub>	<i>T</i> <sub>1</sub>	<i>L</i>	Масса, кг	
65	76,1	2,9	60,3	2,9	89	0,47	
		5,0		4,0		0,78	
		7,1		5,6		1,10	
80	88,9	3,2	48,3	2,6		0,60	
		5,6		3,6		1,00	
		8,0		5,0		1,40	
		3,2	60,3	2,9		0,60	
		5,6		4,0		1,00	
		8,0		5,6		1,40	
100	114,3	3,2	76,1	2,9	0,60		
		5,6		5,0	1,00		
		8,0		7,1	1,40		
100	114,3	3,6	60,3	2,9	102	1,00	
		6,3		4,0		1,70	
		8,8		5,6		2,30	
		3,6	76,1	2,9		1,00	
		6,3		5,0		1,70	
		8,8		7,1		2,30	
125	139,7	3,6	88,9	3,2	127	1,00	
		6,3		5,6		1,70	
		8,8		8,0		2,30	
125	139,7	4,0	114,3	3,6		140	1,70
		6,3		6,3			2,60
		10,0		8,8			4,10
150	168,3	4,0	88,9	2,9	127		1,70
		6,3		5,0			2,60
		10,0		7,1			4,10
		4,5	114,3	3,2		140	2,50
		7,1		5,6			3,90
		11,0		8,8			6,00
150	168,3	4,5	114,3	3,6	140		2,50
		7,1		6,3			3,90
		11,0		8,8			6,00
150	168,3	4,5	139,7	4,0		140	2,50
		7,1		6,3			3,90
		11,0		10,0			6,00
200	219,1	6,3	114,3	3,6	152		5,10
		8,0		6,3			6,30
		12,5		8,8			9,70

Продолжение таблицы 1

Размеры в миллиметрах

DN	<i>D</i>	<i>T</i>	<i>D</i> <sub>1</sub>	<i>T</i> <sub>1</sub>	<i>L</i>	Масса, кг
200	219,1	6,3 8,0 12,5	139,7	4,0 6,3 10,0	152	5,10 6,30 9,70
		6,3 8,0 12,5	168,3	4,5 7,1 11,0		5,10 6,30 9,70
250	273,0	6,3 10,0	139,7	4,0 6,3	178	7,40 12,00
		6,3 10,0	168,3	4,5 7,1		7,40 12,00
		6,3 10,0	219,1	6,3 8,0		7,40 12,00
300	323,9	7,1 10,0	168,3	4,5 7,1	203	11,00 16,00
		7,1 10,0	219,1	6,3 8,0		11,00 16,00
		7,1 10,0	273,0	6,3 10,0		11,00 16,00
350	355,6	8,0 11,0	219,1	6,3 8,0	330	23,00 31,00
		8,0 11,0	273,0	6,3 10,0		23,00 31,00
		8,0 11,0	323,9	7,1 10,0		23,00 31,00
400	406,4	8,8 12,5	273,0	6,3 10,0	356	31,00 43,00
		8,8 12,5	323,9	7,1 10,0		31,00 43,00
		8,8 12,5	355,6	8,0 11,0		31,00 43,00
450	457,0	10,0	323,9	7,1	381	42,00
			355,6	8,0		
			406,4	8,8		
500	508,0	11,0	355,6	8,0	508	65,00
			406,4	8,8		
			457,0	10,0		

**ГОСТ 17378—2001**

Окончание таблицы 1

Размеры в миллиметрах

DN	D	T	D <sub>1</sub>	T <sub>1</sub>	L	Масса, кг
600	610,0	12,5	406,4	8,8	508	94,0
			457,0	10,0		
			508,0	11,0		
700	711,0	—	457,0	10,0	610	—
			508,0	11,0		
			610,0	12,5		
800	813,0		508,0	11,0		
			610,0	12,5		
900	914,0		610,0	12,5		
		711,0	—			
		813,0	—			
1000	1016,0	711,0	—			
		813,0	—			
		914,0	—			
Примечание — Масса приведена для справок.						

Таблица 2 — Переходы исполнения 2

Размеры в миллиметрах

DN	D	T	D <sub>1</sub>	T <sub>1</sub>	L	Масса, кг
32	38	2,0	32	2,0	30	0,1
		3,0		3,0		0,2
		4,0		4,0		0,2
		2,0	25	1,6		0,1
		3,0		3,0		0,2
		4,0		3,0		0,2
40	45	2,5	32	1,6	45	0,1
		4,0		3,0		0,2
		5,0		3,0		0,3
		2,5	32	2,0		0,1
		4,0		4,0		0,2
		5,0		5,0		0,3
		2,5	38	2,0		0,1
		4,0		4,0		0,2
		5,0		5,0		0,3
50	57	3,0	25	1,6	45	0,2
		4,0		1,6		0,3
		5,0		3,0		0,3
		6,0		3,0		0,3
				3,0		0,4

Продолжение таблицы 2

Размеры в миллиметрах

DN	D	T	D <sub>1</sub>	T <sub>1</sub>	L	Масса, кг
50	57	3,0	32	2,0	45	0,2
		4,0		2,0		0,3
		5,0		3,0		0,3
		6,0		4,0		0,4
		3,0	38	2,0		0,2
		4,0		4,0		0,3
5,0	4,0	0,3				
6,0	4,0	0,4				
65	76	3,0	45	2,5	60	0,2
		4,0		2,5		0,3
		5,0		4,0		0,3
		6,0		5,0		0,4
		3,0	38	2,0		0,3
		3,5		2,5		0,4
5,0	3,0	0,6				
6,0	3,0	0,6				
7,0	4,0	0,7				
65	76	3,0	45	2,5	70	0,4
		3,5		2,5		0,5
		5,0		4,0		0,6
		6,0		4,0		0,7
		7,0	5,0	0,8		
		3,0	57	3,0		0,3
3,5	3,0	0,4				
5,0	4,0	0,6				
6,0	5,0	0,7				
7,0	6,0	0,8				
80	89	3,5	45	2,5	75	0,6
		6,0		4,0		0,9
		8,0		5,0		1,2
		3,5		57		3,0
		6,0	4,0			0,9
		8,0	5,0	1,2		
3,5	76	3,5	0,6			
6,0		5,0	0,9			
8,0	6,0	1,2				
100	108	4,0	57	3,0	80	0,9
		6,0		4,0		1,2
		8,0		5,0		1,6
		9,0		6,0		1,8
		4,0	76	3,5		0,9
		6,0		5,0		1,2
8,0	6,0	1,6				
9,0	7,0	1,8				

## ГОСТ 17378—2001

Продолжение таблицы 2

Размеры в миллиметрах

DN	$D$	$T$	$D_1$	$T_1$	$L$	Масса, кг
100	108	4,0	89	3,5	80	0,9
		6,0		6,0		1,2
	8,0	8,0		1,6		
	9,0	8,0		1,8		
	114	4,0	57	3,0		1,0
		6,0		4,0		1,3
		8,0	5,0	1,7		
		9,0	6,0	1,9		
114	4,0	76	3,5	1,0		
	6,0		5,0	1,3		
	8,0		6,0	1,7		
	9,0		7,0	1,9		
114	4,0	89	3,5	1,0		
	6,0		6,0	1,3		
	8,0		8,0	1,7		
	9,0		8,0	1,9		
125	133	4,0	57	3,0	100	1,3
		8,0		4,0		2,5
		10,0		5,0		3,1
		5,0	76	3,5		1,6
		8,0		5,0		2,5
	10,0	6,0	3,1			
	133	4,0	89	3,5		1,3
		6,0		5,0		1,9
		8,0		6,0		2,5
		5,0	108	4,0		1,6
8,0		6,0		2,5		
8,0	8,0	2,5				
10,0	9,0	3,1				
133	5,0	114	4,0	1,6		
	8,0		6,0	2,5		
	8,0		8,0	2,5		
	8,0		8,0	2,5		
	10,0		9,0	3,1		
150	159	4,5	57	3,0	75	1,5
		8,0		4,0		2,6
		10,0		5,0		3,2
		12,0	6,0	3,9		
		4,5	76	3,5		1,5
		8,0		5,0		2,6
	10,0	6,0		3,2		
	12,0	7,0	3,9			
	159	159	4,5	89	3,5	130
8,0			6,0		3,9	
10,0			8,0		4,8	
12,0			8,0		5,9	

Продолжение таблицы 2

Размеры в миллиметрах

DN	D	T	D <sub>1</sub>	T <sub>1</sub>	L	Масса, кг	
150	159	4,5	108	4,0	130	2,3	
		8,0		6,0		3,9	
		10,0		8,0		4,8	
			12,0		9,0		5,9
			4,5	114	4,0	130	2,3
			8,0		6,0		3,9
			10,0		8,0		4,8
			12,0		9,0		5,9
			4,5	133	4,0	130	2,3
			8,0		8,0		3,9
			10,0		10,0		4,8
			12,0		10,0		5,9
	168	4,5	57	3,0	75	1,6	
				8,0		4,0	2,7
			10,0	5,0	3,3		
			12,0	6,0	4,0		
			4,5	76	3,5	130	1,6
			8,0		5,0		2,7
		10,0	6,0	3,3			
		12,0	7,0	4,0			
		4,5	89	3,5	130	2,6	
		8,0		6,0		4,1	
		10,0	8,0	5,1			
		12,0	8,0	6,2			
		4,5	108	4,0	130	2,6	
		8,0		6,0		4,1	
		10,0	8,0	5,1			
		12,0	9,0	6,2			
		4,5	114	4,0	130	2,6	
		8,0		6,0		4,1	
		10,0	8,0	5,1			
		12,0	9,0	6,2			
		4,5	133	4,0	130	2,6	
		8,0		8,0		4,1	
		10,0	10,0	5,1			
		12,0	10,0	6,2			
200	219	6,0	57	3,0	95	2,9	
		10,0		4,0		4,6	
12,0	4,0	5,5					
14,0	5,0	6,4					
16,0	6,0	7,3					
		6,0	76	3,5	95	2,9	
		10,0		5,0		4,6	
		12,0		5,0		5,5	
		14,0		6,0		6,4	
		16,0		7,0		7,3	



## ГОСТ 17378—2001

Продолжение таблицы 2

Размеры в миллиметрах

DN	$D$	$T$	$D_1$	$T_1$	$L$	Масса, кг
200	219	6,0	89	3,5	95	2,9
		10,0		5,0		4,6
		12,0		5,0		5,5
		14,0		6,0		6,4
		16,0		8,0		7,3
		6,0	108	4,0		2,9
		10,0		6,0		4,6
		12,0		8,0		5,5
		14,0		8,0		6,4
		16,0		9,0		7,3
		6,0	114	4,0		2,9
		10,0		6,0		4,6
12,0	8,0	5,5				
14,0	8,0	6,4				
16,0	9,0	7,3				
6,0	133	4,0	140	4,4		
10,0		8,0		7,2		
12,0		8,0		8,8		
14,0		10,0		10,0		
16,0		10,0		12,0		
6,0	159	4,5		4,4		
10,0		8,0		7,2		
12,0		10,0		8,8		
14,0		12,0		10,0		
16,0		12,0		12,0		
6,0	168	4,5		4,4		
10,0		8,0		7,2		
12,0		10,0	8,8			
14,0		12,0	10,0			
16,0		12,0	12,0			
250	273	7,0	108	4,0	140	6,0
		10,0		6,0		8,5
		12,0		8,0		10,0
		14,0		8,0		12,0
		16,0		9,0		13,0
		18,0	9,0	15,0		
		7,0	114	4,0		6,0
		10,0		6,0		8,5
		12,0		8,0		10,0
14,0	8,0	12,0				
16,0	9,0	13,0				
18,0	9,0	15,0				
7,0	133	4,0	6,0			
10,0		6,0	8,5			
12,0		8,0	10,0			
14,0		8,0	12,0			
16,0		10,0	13,0			
18,0	10,0	15,0				

Продолжение таблицы 2

Размеры в миллиметрах

DN	D	T	D <sub>1</sub>	T <sub>1</sub>	L	Масса, кг
250	273	7,0	159	4,5	180	8,3
		10,0		8,0		12,0
		12,0		10,0		14,0
		14,0		10,0		16,0
		16,0		12,0		18,0
		18,0		12,0		20,0
		7,0	168	4,5		8,3
		10,0		8,0		12,0
		12,0		10,0		14,0
14,0	10,0	16,0				
16,0	12,0	18,0				
18,0	12,0	20,0				
7,0	219	6,0	8,3			
10,0		8,0	12,0			
12,0		10,0	14,0			
14,0		12,0	16,0			
16,0		14,0	18,0			
18,0		16,0	20,0			
300	325	8,0	108	4,0	140	9,0
		10,0		4,0		11,0
		12,0		6,0		16,0
		14,0		6,0		18,0
		16,0		8,0		20,0
		18,0		8,0		23,0
		22,0		9,0		28,0
		8,0	114	4,0		9,0
		10,0		4,0		11,0
		12,0		6,0		16,0
		14,0		6,0		18,0
		16,0		8,0		20,0
		18,0		8,0		23,0
		22,0		9,0		28,0
		8,0	133	5,0		11,0
		10,0		6,0		13,0
		12,0		8,0		16,0
		14,0		8,0		18,0
		16,0		8,0		20,0
		18,0		10,0		23,0
22,0	10,0	28,0				
8,0	159	4,5	11,0			
10,0		6,0	14,0			
12,0		8,0	16,0			
14,0		8,0	18,0			
16,0		10,0	20,0			
18,0		10,0	23,0			
22,0		12,0	28,0			
8,0	168	4,0	11,0			
10,0		6,0	14,0			
12,0		8,0	16,0			
14,0		8,0	18,0			

## ГОСТ 17378—2001

Продолжение таблицы 2

Размеры в миллиметрах

DN	D	T	D <sub>1</sub>	T <sub>1</sub>	L	Масса, кг			
300	325	16,0	168	10,0	140	20,0			
		18,0		10,0		23,0			
		22,0		12,0		28,0			
		8,0	219	7,0	180	11,0			
		10,0		8,0		14,0			
		12,0		10,0		17,0			
		14,0		10,0		20,0			
		16,0		12,0		22,0			
		18,0		14,0		25,0			
22,0	16,0	31,0							
8,0	273	7,0	180	11,0					
10,0		10,0		14,0					
12,0		12,0		17,0					
14,0		12,0		20,0					
16,0		14,0		22,0					
18,0		16,0		25,0					
22,0	18,0	31,0							
350	377	12,0	159	6,0	220	22,0			
		16,0		8,0		29,0			
		20,0		10,0		35,0			
		24,0		12,0		42,0			
		26,0		12,0		45,0			
		12,0	168	6,0		220	22,0		
		16,0		8,0			29,0		
		20,0		10,0			35,0		
		24,0		12,0			42,0		
		26,0		12,0			45,0		
		12,0	219	8,0			220	22,0	
		16,0		10,0				29,0	
		20,0		12,0				35,0	
		24,0		14,0				42,0	
		26,0		16,0				45,0	
		10,0	273	7,0				220	20,0
		12,0		10,0					24,0
		14,0		12,0					28,0
		16,0		12,0					31,0
		20,0		16,0					38,0
24,0	18,0	45,0							
26,0	18,0	49,0							
10,0	325	8,0	220	20,0					
12,0		10,0		24,0					
14,0		12,0		28,0					
16,0		16,0		31,0					
20,0		18,0		38,0					
24,0		22,0		45,0					
26,0	22,0	49,0							
400	426	12,0		159	8,0	220			37,0
		16,0			10,0		53,0		
		20,0			10,0		65,0		

Окончание таблицы 2

Размеры в миллиметрах

DN	D	T	D <sub>1</sub>	T <sub>1</sub>	L	Масса, кг
400	426	22,0	159	10,0	220	71,0
		26,0		12,0		83,0
		28,0		12,0		89,0
		12,0	168	8,0		37,0
		16,0		10,0		53,0
		20,0		10,0		65,0
		22,0		10,0		71,0
		26,0		12,0		83,0
		28,0		12,0		89,0
		12,0	219	8,0		32,0
		16,0		10,0		45,0
		20,0		12,0		56,0
22,0	12,0	61,0				
26,0	14,0	72,0				
28,0	16,0	76,0				
12,0	273	10,0	27,0			
16,0		12,0	36,0			
20,0		14,0	44,0			
22,0		14,0	48,0			
26,0		18,0	56,0			
28,0		18,0	59,0			
10,0	325	8,0	23,0			
12,0		10,0	27,0			
14,0		12,0	31,0			
16,0		12,0	36,0			
20,0		16,0	44,0			
22,0		18,0	48,0			
26,0		20,0	56,0			
28,0		22,0	59,0			
10,0	377	10,0	23,0			
12,0		12,0	27,0			
14,0		14,0	31,0			
16,0		16,0	36,0			
20,0		20,0	44,0			
22,0		20,0	48,0			
26,0		24,0	56,0			
28,0		26,0	59,0			
500	530	12,0	377	10,0	300	46,0
		14,0		12,0		54,0
		16,0		12,0		61,0
		20,0		16,0		75,0
		22,0		20,0		81,0
		26,0		22,0		94,0
		12,0	426	10,0		46,0
		14,0		12,0		54,0
		16,0		16,0		61,0
		20,0		16,0		75,0
		22,0		20,0		81,0
		26,0		22,0		94,0

Примечание — Масса приведена для справок.

## ГОСТ 17378—2001

Примеры условных обозначений:

- концентрического перехода исполнения 1,  $D = 76,1$  мм,  $T = 2,9$  мм,  $D_1 = 48,3$  мм,  $T_1 = 2,6$  мм из стали марки Р9:

*Переход К-1-76,1 · 2,9-48,3-2,6-Р9 ГОСТ 17378—2001*

- эксцентрического перехода исполнения 2,  $D = 76$  мм,  $T = 3,0$  мм,  $D_1 = 45$  мм,  $T_1 = 2,5$  мм из стали марки 20:

*Переход Э-76 · 3-45 · 2,5 ГОСТ 17378—2001*

- то же, из стали марки 09Г2С для трубопроводов, подконтрольных органам надзора:

*Переход П Э-76 · 3-45 · 2,5-09Г2С ГОСТ 17378—2001*

4.2 Толщина стенки переходов в неторцевых сечениях должна быть не менее  $T_1$  при наружном диаметре сечения не более  $1,1D_1$ , а в остальных сечениях — не менее  $T$ .

4.3 Радиусы сопряжения поверхностей переходов (рисунок 1) должны соответствовать указанным в таблице 3.

Т а б л и ц а 3 — Радиусы сопряжения поверхностей переходов

Тип перехода	$r_1$	$r_2$
	не менее	
Концентрический	$0,4D$	$0,4D_1$
Эксцентрический	$0,3D$	$0,3D_1$

4.4 По согласованию между изготовителем и потребителем (заказчиком) допускается изготовление переходов других размеров.

## 5 Технические условия

Технические условия — по ГОСТ 17380.

---

УДК: 621.643.4:006.354

МКС 23.040.40

Г18

ОКП 14 6800

Ключевые слова: трубопроводы, детали трубопроводов, трубопроводные переходы, конструкция, размеры

---